



TEA-101D TRANSMITTER

Programmable temperature transmitter with 4-20 mA output

Instruction Manual

Instruction manual for use of TEA-101D transmitter

Transmitter is designed for measurement of ambient air temperature at °C or °F. Measuring temperature sensor is non-removable instrument part. Measured temperature is displayed on LCD display. It is possible to switch OFF the LCD display. Transmitter is connected to circuitry by current loop. Please read instruction manual before the first device connection.

All transmitter setting is performed by means of the PC connected via the optional communication cable (not included in delivery). Program *Tsensor* for transmitter setting is available at ATAL B.V.. Program enables to set measured range and on/off the LCD display. It supports make the adjustment of the device too. This procedure is described at file „*Calibration manual.pdf*“ which is installed commonly with the software.

Device setting from the manufacturer

Transmitter is set from the manufacturer to the following parameters:

value at output II: temperature, range 4 – 20 mA corresponds to -30 to +80 °C

display: switched ON

Modification of the setting is possible to do by means of the PC using procedure described at the end of this document.

Installation of the transmitter

Transmitter is designed for wall mounting. There are two mounting holes at the sides of the case. Don't connect transmitter while power supply voltage is on. Interconnection terminals are accessible after unscrewing four screws and removing the lid. Lace the cable through a gland at the case wall. Connect the cable to terminals with respecting the signal polarity (see figure). Terminals are self-clamping and can be opened by a suitable screwdriver. For the opening, insert the screwdriver to upper terminal hole and lever by him. Do not remember to tighten glands and case lid with inserted packing after cables connecting. It is necessary for warranting of protection IP65.

It is recommended to use shielded copper cable (e.g. SYKFY) with outside diameter of the cable must be from 3.5 to 8 mm, maximal length 1200m. The cable must be located at indoor rooms (probe is not protected for outdoor use). The cable should not be led in parallel along power cabling. Safety distance is up to 0.5 m otherwise undesirable induction of interference signals can appear.

In the application where air flow is too low it is possible that measurement accuracy may be a bit lower (in decimals of °C) due to undesirable warm influence which develops in transmitter electronics because of its own power dissipation. Mechanical construction of the transmitter and working position is minimizing this effect, but in critical applications we recommend to use optimal value of load resistor R_z (see graph no.2 below). It minimizes power dissipation to minimal value. If U_{ss} and R_z are set, it is possible to do it by inserting of suitable serial resistor into current loop at estimation device side.

Electrical system (wiring) may do only worker with required qualification by rules in operation.

Dimensions

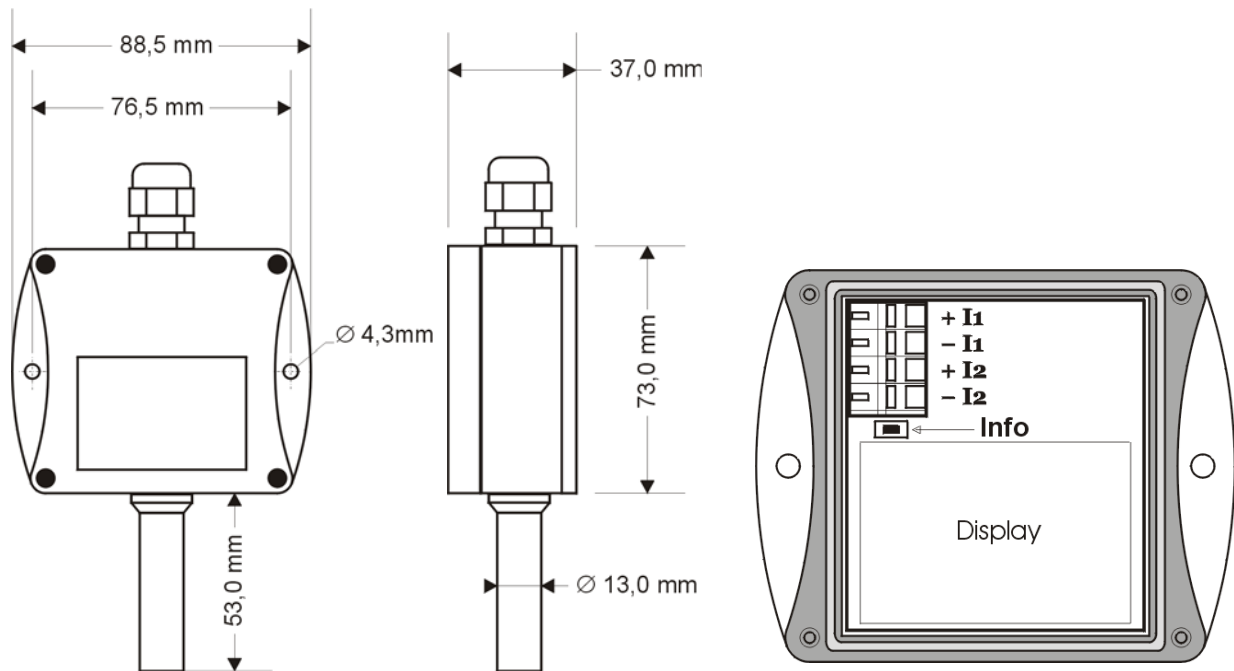

Typical application wiring

Calculation of minimum power voltage U_{ss} for proper operation:

$$U_{ss \min} > U_0 \min + I_{\max} * R_z,$$

where: $U_0 \min = 9 \text{ V}$

I_{\max} ... approximately 20 mA

R_z ... sensing resistor (shunt)

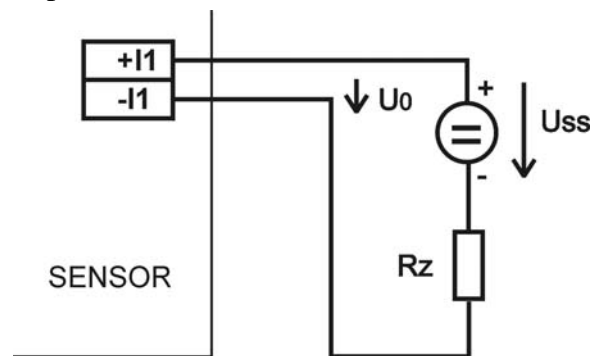

Choice of optimal power voltage and load resistor for current loop.

area no 1..... transmitter doesn't work correctly

area no 2..... optimal U_{ss} and R_z

area no 3..... transmitter is working but it is possible to see undesirable warm influence.

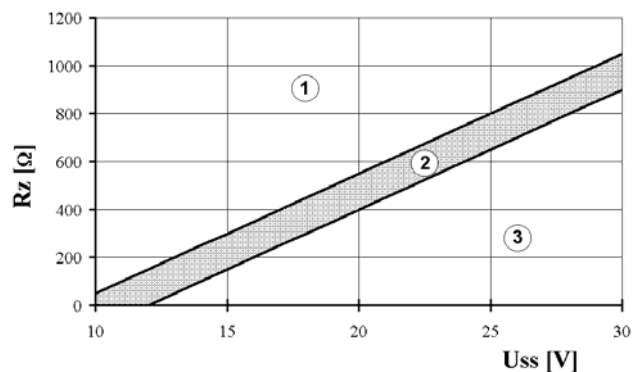

LCD Info mode

Several settings of installed transmitter are possible to verify without using computer. It is necessary to connect at least power of current loop I1.

Unscrew the transmitter lid and shortly press button between display and interconnection terminals by means of a tool (e.g. screwdriver).



Range and type of value for output 1 (current loop I1 = symbol „1“ on display). Type of value, assigned to output 1, is indicated by displayed unit (here °C = temperature). Upper line displays current value corresponding to measured value (lower line). Here 4 mA corresponds to -30 °C



Press button again to get value for upper point (same output, same value) similarly as at previous point. Here 20 mA corresponds to 80 °C.

Press button again to end info mode and display actual measured values.

Notice: during info mode no measurement and no output current generation proceed. The transmitter stays at info mode 15 s and then automatically goes back to measuring cycle.

Readings on LCD display

°C, °F

Reading next to this symbol is measured temperature or error state of value.

Technical parameters:

Analog output:

Current loop with range from 4 to 20 mA

Current output in case of error: <3.8 mA or >24 mA

Measuring parameters:

Ambient temperature (internal RTD sensor Pt1000/3850ppm):

Measuring range: -30 to +80 °C

Display resolution: 0.1 °C

Accuracy: ± 0.4 °C (For values on LCD display. For values on analog output too, if selected output range is set inside measuring range).

Power: **9 to 30 V dc**, maximum ripple 0.5 %

Response time (air flow approximately 1 m/s):

temperature: $t_{90} < 4$ min (temperature step 20 °C)

Recommended interval of calibration: 2 years

Measuring interval and LCD display refresh: 0.5 s

Communication with computer: via USB port by means of USB communication cable ATS-AC02

Protection: IP65

Operating conditions:

Operating temperature range: -30 to +80 °C, over +70°C switch LCD display OFF

Operating humidity range: 0 to 100 %RH

Outer characteristics in accordance with EN 33-2000-3:

normal environment with the specifications: AE1, AN1, BE1

Working position: the stem downwards

Electromagnetic compatibility: complies EN 61326-1

Not allowed manipulations:

It is not allowed to operate the device under other than specified conditions in technical parameters. Devices are not designed for locations in chemically aggressive environment.

Storing conditions: temperature -30 to +80 °C, humidity 0 to 100 %RH without condensation

Dimensions: 89 x 73 x 37 mm, stem length 53 mm

Weight: approximately 150 g

Material of the case: ABS

Procedure of modification of transmitter adjustment:

- device adjustment is performed by means of the optional ATS-AC02 communication cable, connected to USB port of the PC.
- It is necessary to have installed configuration program Tsensor on the PC, It is free available at Atal B.V.. During installation please take care about installation of driver for USB communication cable
- Connect ATS-AC02 communication cable to the PC. Installed USB driver detect connected cable and create virtual COM port inside the PC.
- Unscrew four screws of the device lid a remove the lid. If device is already installed to measuring system, disconnect leads from terminals
- Connect ATS-AC02 communication cable to the device. Display must light up, or at least must light up all symbols for one second (if LCD was switched OFF by program before).
- Run installed Tsensor program and select corresponding communication COM port (as described above).
- When new setting is saved and finished, disconnect the cable from the device, connect leads into its terminals and place the lid back to the device.

Error states of the device

Device continuously checks its state during operation. In case error is found LCD displays corresponding error code:

Error 0

First line displays „Err0“.

Check sum error of stored setting inside device's memory. Output value is < 3.8 mA. This error appears if incorrect writing procedure to device's memory occurred or if damage of calibration data appeared. At this state device does not measure and calculate values. It is a serious error, contact distributor of the instrument to fix.

Error 1

Measured value is over upper limit of allowed full scale range. There is a reading „Err1“ on LCD display. Output value is about 24.5 mA. This state appears if measured temperature is higher than approximately 600°C (i.e. high non-measurable resistance of temperature sensor, probably opened circuit).

Error 2

There is a reading „Err2“ on LCD display. Output value is about 3.8 mA. Measured value is below lower limit of allowed full scale range. This state appears if measured temperature is lower than approximately -210°C (i.e. low resistance of temperature sensor, probably short circuit).

Error 3

There is a reading „Err3“ on LCD display upper line.

Error of internal A/D converter appeared (converter does not respond, probably damage of A/D converter). No measurements proceed. Output value is about 3.8 mA. It is a serious error, contact distributor of the instrument.

End of operation

Device itself (after its life) is necessary to liquidate ecologically!

Technical support and service

Technical support and service is provided by distributor.

Notes:
